

Swivel unit

Rotary drive, swivel range 180°,
heavy duty

KSD...

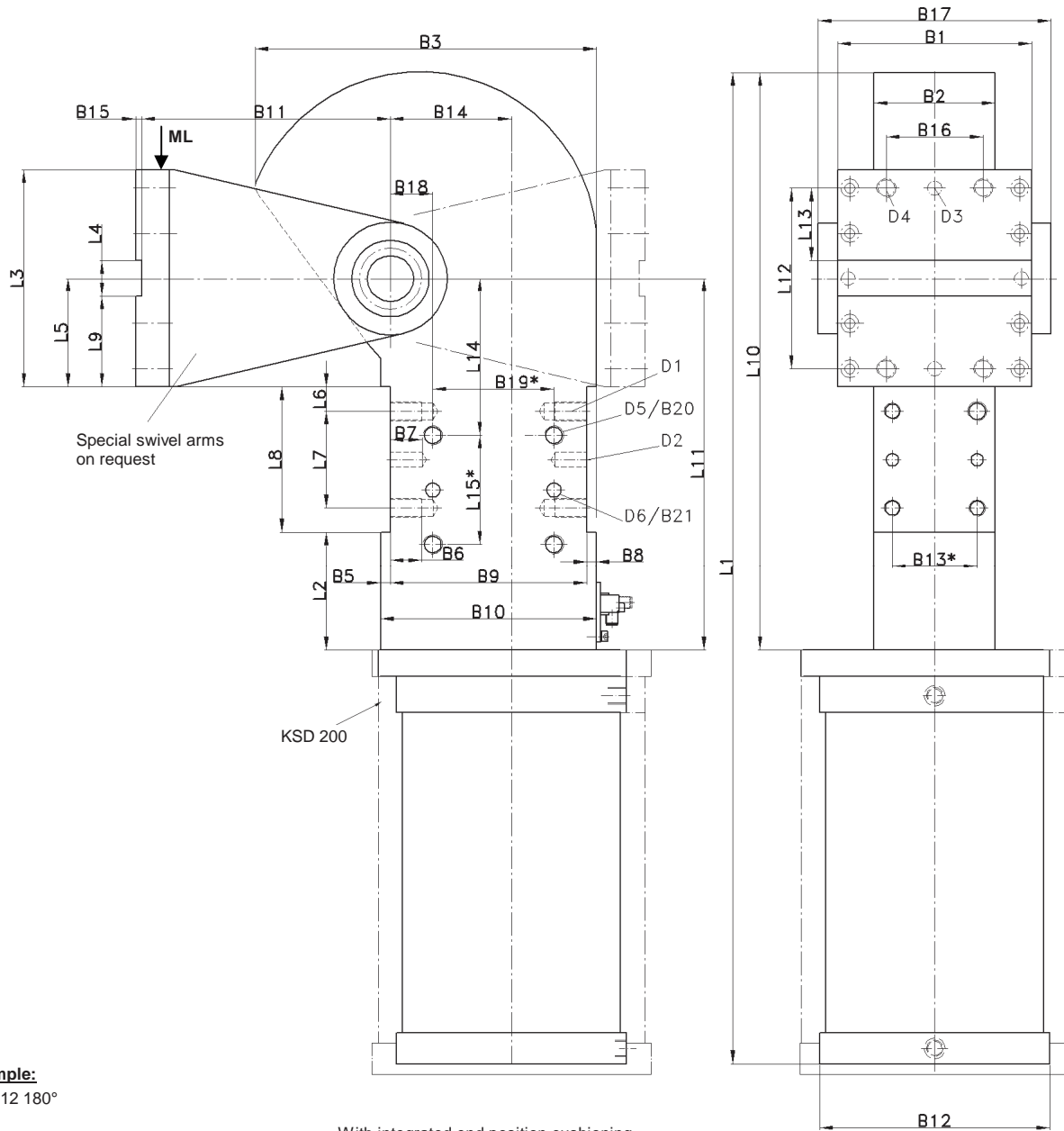

Ordering example:

KSD160 A10 T12 180°

KSD: Type
160: Piston Ø
A10: Swivel arm version
T12: Sensing system
180°: Opening angle

With integrated end position cushioning.

Optionally available with safety blocking system.

Attention!

External throttle check valves must be provided on assembly.
They are not included in the scope of delivery.

Ordering example Tünkers sensing systems:

...T00 without sensing
...T12 Inductive sensor 24 V, 1 output
with integrated LED's

*Tolerance for dowel holes ± 0.02, for threaded holes ± 0.1.

Medium: Air max. 8 bar, operation permitted with oil-free air.

Type	Torque caused by load ML max. at 6 bar	Accord. to piston Ø (mm)	Weight (kg)
KSD 160	500 Nm	160	90
KSD 200	750 Nm	200	110

Type	B1	B2 ±0,1	B3	B5	B6	B7	B8	B9 ±0,1	B10	B11	B12	B13*	B14	B15	B16	B17	B18 ±0,05	B19*	B20	B21	D1	D2 H7
KSD 160	176	100	315	8	26	26	8	162	178	205	177	70	85	5	80	206	35	100	16	12	M16	12
KSD 200	176	100	315	8	26	26	8	162	178	205	220	70	85	5	80	206	35	100	16	12	M16	12

Type	D3 H7	D4	D5	D6 H7	L1 at 180° open. angle ~	L2	L3	L4 +0,1	L5 ±0,1	L6 ±0,1	L7 ±0,1	L8 +0,1	L9	L10 ~	L11	L12 *	L13	L14 ±0,05	L15*
KSD 160	12	M16	M16	12	1020	108	178	30	90	20	80	120	74	490	318	150	60	130	90
KSD 200	12	M16	M16	12	1030	108	178	30	90	20	80	120	74	490	318	150	60	130	90