

Retractable Locating Pin

for central pin assembly, toggle locked end position,
pneumatic sensing system

SZV.1 40 A01 T08

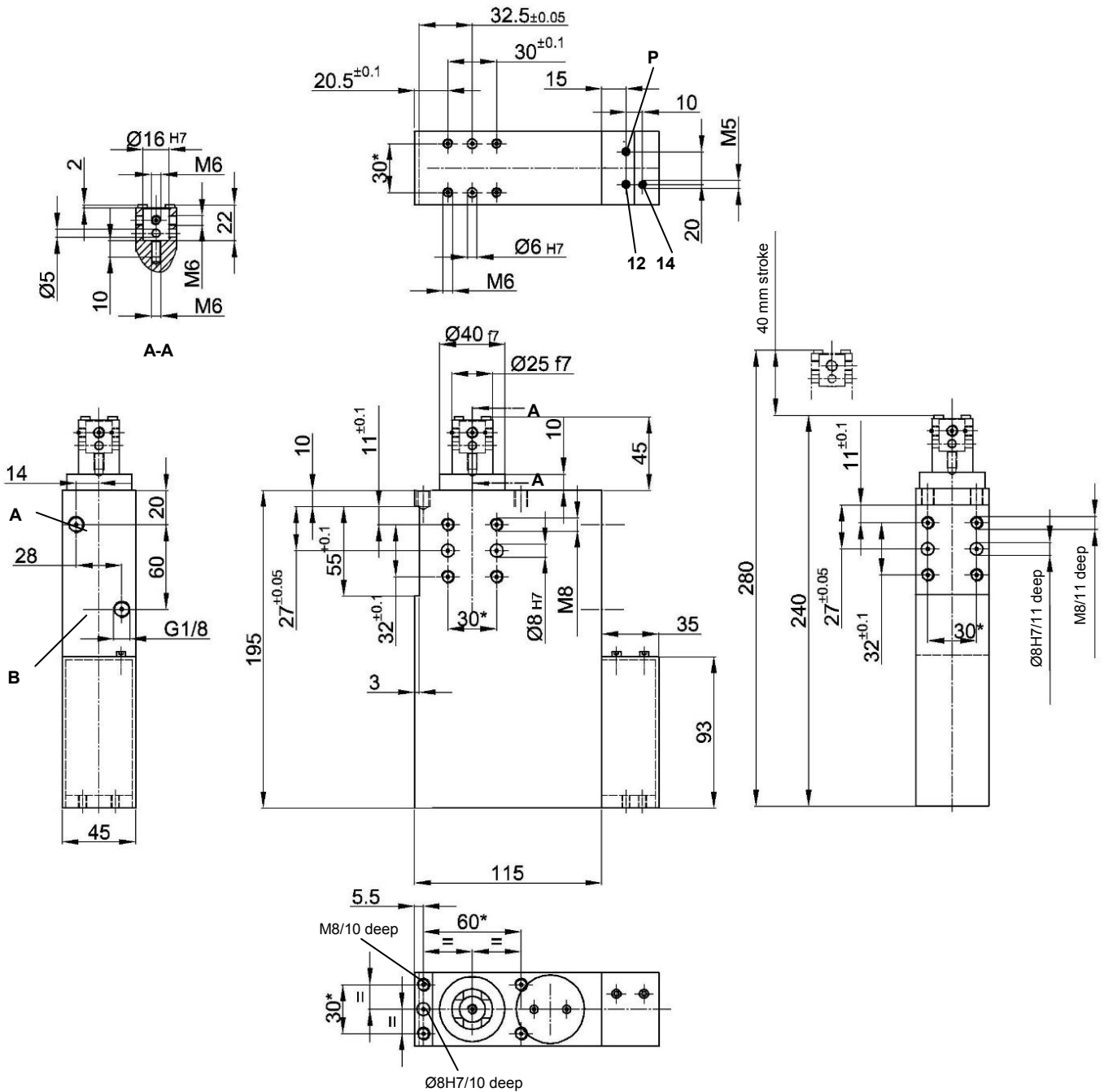

Ordering example

SZV.1 40 Z A01 T08

SZV.1 40 A01: Type
T08: Sensing system

Ordering example Tünkers sensing system:

...T08 Pneumatic sensing

Connections pneumatic sensing T08:

A: retract
B: extend
P: pressure connection for sensing M5
14: control system A M5
12: control system B M5

Further retractable locating pins with hand lever (Z) respectively with pneumatic sensing T08:

SZV.1 40 A02
SZV.1 40 A10
SZV.1 40 A..2
SZV.1 40 B

Shearing force: min. 500 N at 6 bar, max. in end position 3000 N
Tensile force: min. 420 N at 6 bar, max. tear-off force 3000 N
Holding force: 5 kN
Shear load: 300 N
Piston Ø: 40
Weight: 3.6 kg

*Tolerance for dowel holes ± 0.02 , for threaded holes ± 0.1 .
Medium: Air, max. 6 bar, operation permitted with oil-free air.

Attention!

External throttle check valves must be provided on assembly.
They are not included in the scope of delivery!