

# Mini Swivel Clamp

Swivel range 90°

# SCBM 25

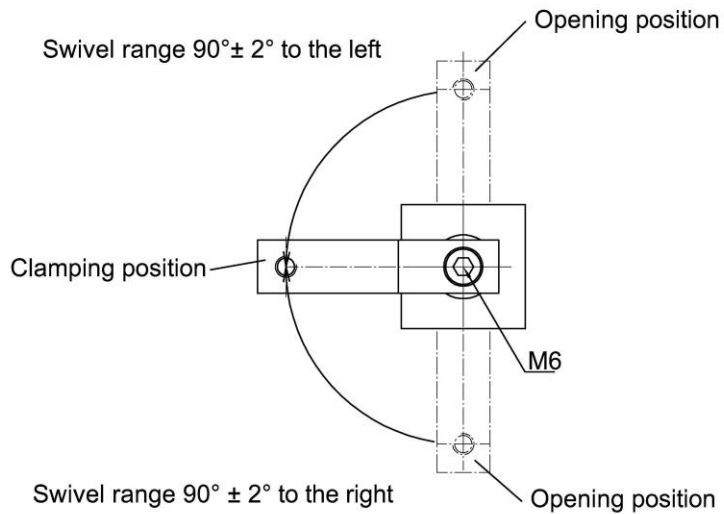
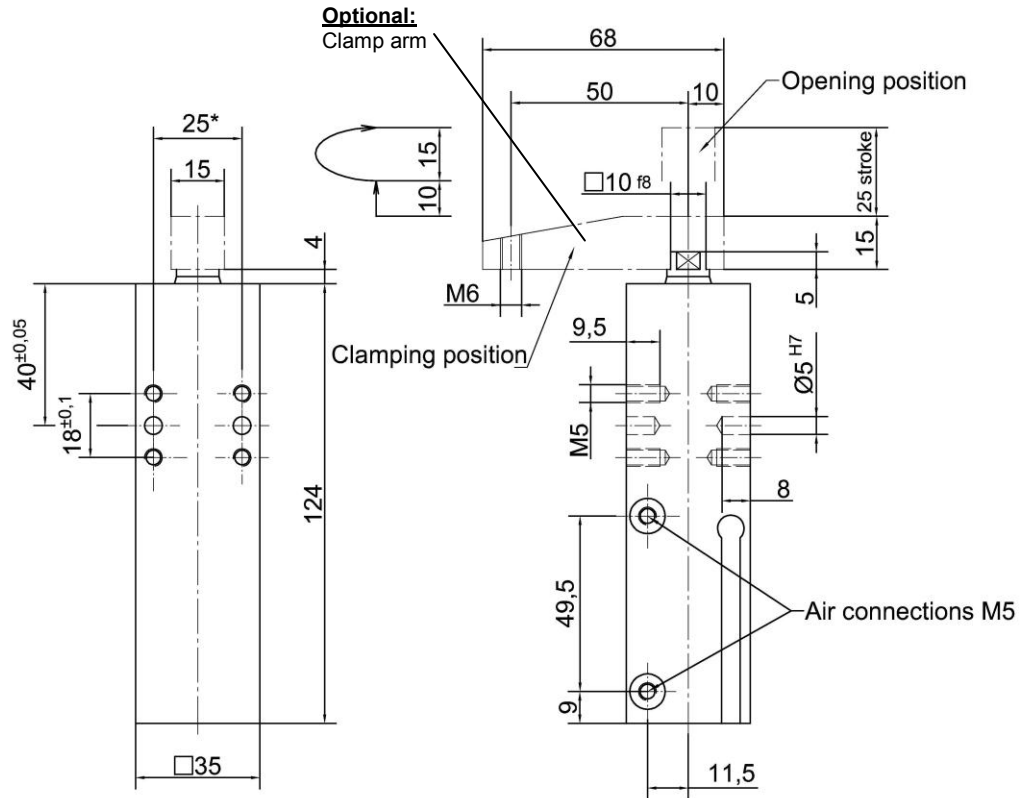

**Ordering example:**

SCBM 25-25 90° L T03

SCBM 25-25: Type  
 90° L: Rotational direction left (R = right)  
 T03: Sensing system

**Ordering example Tünkers sensing system:**

...T03 Magnetic sensing, prepared for sensing

**Accessories:**

Clamp arm, article no. 278068

**Option:**

Magnetic switches type „AFS T03“ (2 pieces, order no. 368428) must be ordered separately; not included in the scope of delivery!

**Attention:**

External throttle check valves must be provided on assembly. They are not included in the scope of delivery!

Type	Clamping force at 5 bar Rod extended	Clamping force at 5 bar Rod retracted	Weight incl. clamp arm (kg)
SCBM 25-25	220 N	170 N	0.6