

# Mini Pneumatic Power Clamp

for horizontal mounting

PKG 16-25

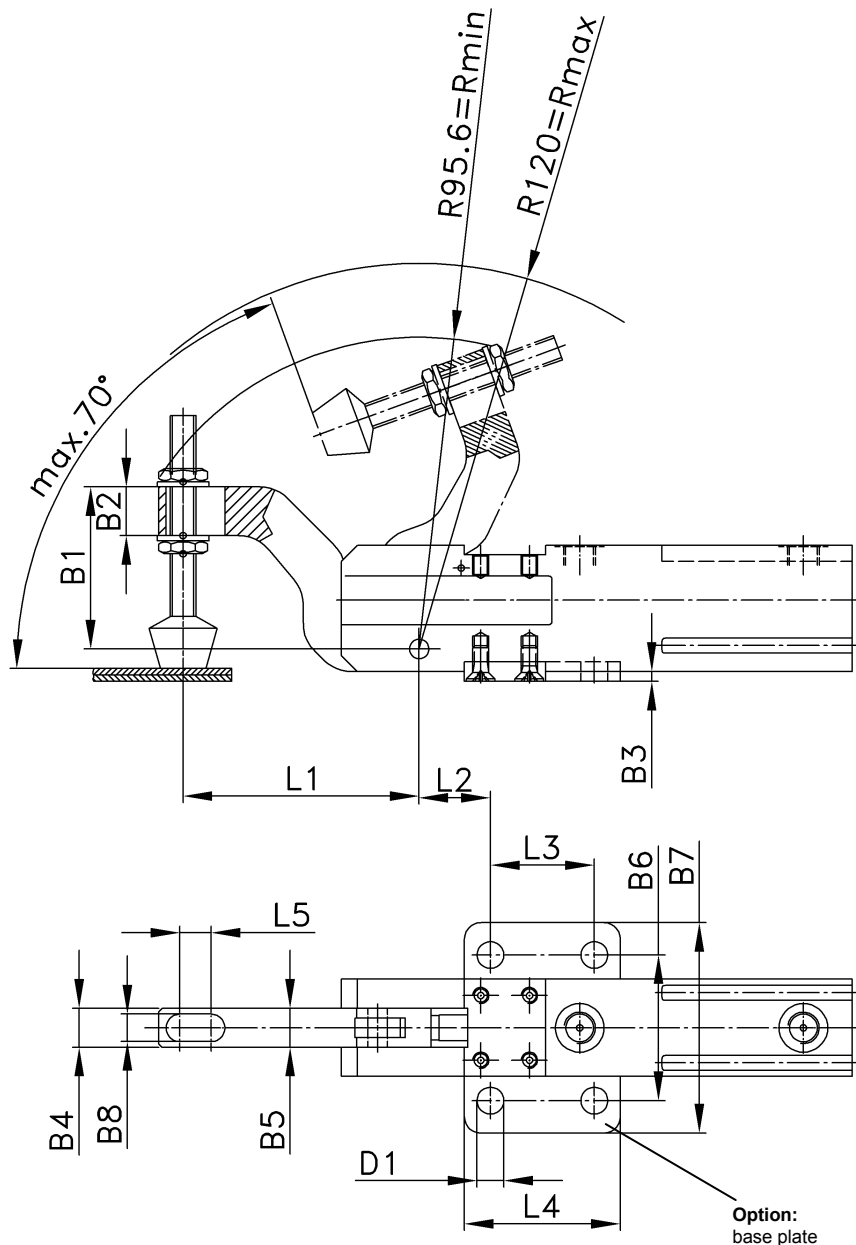

**Ordering example:**

PKG 20 ZL A17 GP T03

PKG: Type  
 20: Piston Ø  
 ZL: Option: hand lever left (ZR = right)  
 A17: Clamp arm version  
 GP: Option: base plate  
 T03: Sensing system  
 45°: Opening angle

**Standard opening angles:**

45°, 60°, 70°

For further measurements see data sheet PKS 16.1-25.1.

For details of the hand lever please see data sheet PKS 16.1-25.1 ZL/ZR.

**Ordering example Tünkers sensing systems:**

...T03 Magnetic sensing, applicable for sensing  
 ...T23 Magnetic sensing, including 2 magnetic switches mounted on clamp  
 ...T23/M12 Magnetic sensing, including 2 magnetic switches with M12 connections mounted on clamp

\*Tolerance for dowel holes ± 0.02, for threaded holes ± 0.1.

**Attention:**

External throttle check valves must be provided on assembly. They are not included in the scope of delivery!

Type	Clamping moment at 5 bar (Nm)	Holding torque max. (Nm)	Working pressure in oil-free air (bar)	Maximum pressure in oil-free air (bar)	Connection (G)	Opening and closing time (approx. sec.)	Weight ~ (kg)
PKG 16	8	25	5	6	M5	1	0.3
PKG 20	15	54	5	6	G1/8	1	0.5
PKG 25	25	75	5	6	G1/8	1	0.8

Type	L1	L2	L3	L4 +0.1	L5	B1	B2	B3	B4	B5	B6*	B7*	B8	D1 Ø
PKG 16	50	16	32	48	4	33	12	3	10	10	45	65	6.5	5
PKG 20	73	22	32	48	10.5	50	15	2.5	12	12	45	65	8.5	8.3
PKG 25	83	26.5	45	64	19.5	52	12	4	16	16	50	70	8.5	8.5