

Pneumatic marking unit

with stamping tool 8 digit, 6 mm high,
last 3 digits changing automatically

PFS 400-60 PO 6-8/A3 (260264)

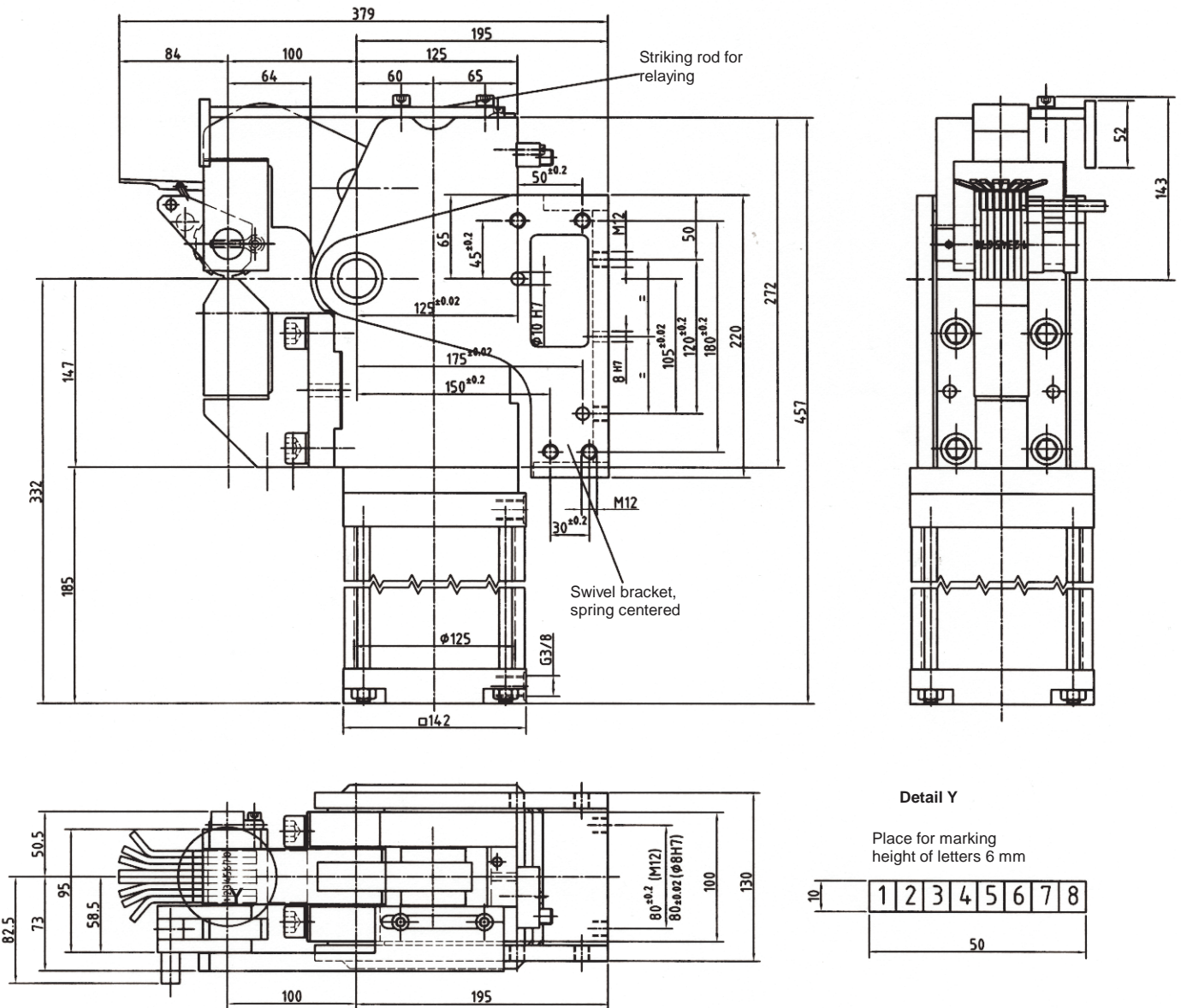

Ordering example:

PFS 400-60 PO 6-8/A3

PFS 400: Type
60: Distance of load center
PO: Stamping tool at the top
6: Height of letters (mm)
8: Number of digits
A3: The last 3 digits are changing automatically

Technical data:

Pressing force: 50 kN
Working pressure: 5 bar
Distance of load center: approx. 60 mm¹
Medium: Compressed air
Tool: Stamping tool with 8-digit, 6 mm high, the last 3 digits are changing automatically via switch rod ²
Opening angle: 30°

¹Further distances of load center on request.

²For further stamping tool versions see data sheet "P...".

* Tolerance for dowel holes ± 0,02, for threaded holes ± 0,1.

Medium: Air, max. 6 bar, operation permitted with oil-free air.

Ordering example Tünkers sensing systems:

T12 Inductive sensor 24 V 1 output with integrated LED's
T08 Pneumatic sensing, 1 pressure pipe