



Spare Parts List

Welding clamp
WS 63 - 100

Spare Parts

05/09

Pos.	Part-No.	Quantity	Description	Type	
1	243284	1.00	clamp	see separate data sheet	
2	243076	1.00	guide unit	see separate data sheet	
4	205009	1.00	console	WS 63	
6	205955	1.00	side part left	WMS 80	
7	214624	1.00	side part right	WMS 80	
8	203372	2.00	flange	K 63 A10	
10	230140	1.00	lower E-carrier	WS 63	
11	228285	1.00	upper E-carrier	WS 63	
15	225186	4.00	insolation bush	WMS 63, 100	
16	225188	1.00	insolation plate	WMS 63, 100	
17	229964	1.00	insolation plate	WS 63	
18	225187	12.00	insolating ring	WMS 63, 100	
19	227474	12.00	hex. socket head cap screw	M 6 x 16 DIN 7984	
20	200221	4.00	hex. socket head cap screw	M 8 x 25 DIN 912	
21	200224	4.00	hex. socket head cap screw	M 8 x 30 DIN 912	
22	200005	1.00	hexagon bolt	M 8 x 30 DIN 931	
23	220462	1.00	hexagon lock nut	M 8 DIN 936	
24	220321	12.00	washer	6,4 DIN 125	
25	220322	4.00	washer	8,4 DIN 125	
	225761	2.00	electrode cap	WS 63	
	229929	2.00	electrode shank	WS 63 A100	
	229930	2.00	coolant tube	M 8 – 63,5 long	
	229980	1.00	bush	WS 63	

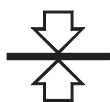

TÜNKERS®
SPANNSYSTEME

TÜNKERS® Maschinenbau GmbH
Am Rosenkoth 8 • 40880 Ratingen
Postfach 10 17 16 • 40837 Ratingen
Tel. 02102 4517-0 • Fax 02102 445808
Internet www.tuenkers.de



Spare Parts List

Welding clamp
WS 63 - 150

Spare Parts

05/09

Pos.	Part-No.	Quantity	Description	Type	
1	243284	1.00	clamp	see separate data sheet	
2	243076	1.00	guide unit	see separate data sheet	
4	205009	1.00	console	WS 63	
6	205955	1.00	side part left	WMS 80	
7	214624	1.00	side part right	WMS 80	
8	203372	2.00	flange	K 63 A10	
10	227644	1.00	lower E-carrier	WS 63	
11	227645	1.00	upper E-carrier	WS 63	
13	227648	2.00	clamping piece	WS 63	
15	225186	2.00	insolation bush	WS 63	
16	225188	1.00	insolation plate	WMS 63, 100	
17	229964	1.00	insolation plate	WMS 63	
18	225187	1.00	insolating ring	WMS 63	
19	227474	12.00	hex. socket head cap screw	M 6 x 16 DIN 7984	
20	200221	4.00	hex. socket head cap screw	M 8 x 25 DIN 912	
21	200224	5.00	hexagon lock nut	M 8 x 30 DIN 912	
22	200005	1.00	hexagon bolt	M 8 x 30 DIN 931	
23	220462	1.00	washer	M 8 DIN 936	
24	220321	12.00	washer	6,4 DIN 125	
25	220322	4.00	hexagon nut	8,4 DIN 125	
	225762	2.00	thread shank	WS 63	
	225763	2.00	electrode shank	WS 63	
	225761	2.00	electrode cap	WS 63	
	242964	2.00	electrode carrier	WS 63	
	227484	2.00	coolant tube	M 8 – 50 long	
	227485	2.00	coolant tube	M 8 – 60 long	
	227486	2.00	sealing ring	Ø 30/21,5 x 2 DIN 7603	
	227480	2.00	o-ring	25,0 x 2,5	
	229980	1.00	bush	WS 63	

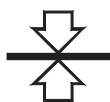

TÜNKERS®
SPANNSYSTEME

TÜNKERS® Maschinenbau GmbH
Am Rosenkoth 8 • 40880 Ratingen
Postfach 10 17 16 • 40837 Ratingen
Tel. 02102 4517-0 • Fax 02102 445808
Internet www.tuenkers.de



Spare Parts List

Welding clamp
WS 63 - 200

Spare Parts

05/09

Pos.	Part-No.	Quantity	Description	Type	
1	243284	1.00	clamp	see separate data sheet	
2	243076	1.00	guide unit	see separate data sheet	
4	205009	1.00	console	WS 63	
6	205955	1.00	side part left	WMS 80	
7	214624	1.00	side part right	WMS 80	
8	203372	2.00	flange	K 63 A10	
10	227644	1.00	lower E-carrier	WS 63	
11	227645	1.00	upper E-carrier	WS 63	
13	227648	2.00	clamping piece	WS 63	
15	225186	2.00	insolation bush	WS 63	
16	225188	1.00	insolation plate	WMS 63, 100	
17	229964	1.00	insolation plate	WMS 63	
18	225187	1.00	insolating ring	WMS 63	
19	227474	12.00	hex. socket head cap screw	M 6 x 16 DIN 7984	
20	200221	4.00	hex. socket head cap screw	M 8 x 25 DIN 912	
21	200224	5.00	hexagon lock nut	M 8 x 30 DIN 912	
22	200005	1.00	hexagon bolt	M 8 x 30 DIN 931	
24	220321	12.00	washer	6,4 DIN 125	
25	220322	4.00	washer	8,4 DIN 125	
	242945	2.00	thread shank	WS 63	
	242944	2.00	electrode shank	WS 63	
	242941	2.00	electrode cap	WS 63	
	242966	2.00	electrode carrier	WS 63	
	229930	2.00	coolant tube	M 8 – 50 long	
	242960	2.00	coolant tube	M 8 – 60 long	
	227486	2.00	sealing ring	Ø 30/21,5 x 2 DIN 7603	
	227480	2.00	o-ring	25,0 x 2,5	
	229980	1.00	bush	WS 63	

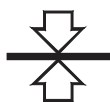

TÜNKERS®
SPANNSYSTEME

TÜNKERS® Maschinenbau GmbH
Am Rosenkoth 8 • 40880 Ratingen
Postfach 10 17 16 • 40837 Ratingen
Tel. 02102 4517-0 • Fax 02102 445808
Internet www.tuenkers.de



Spare Parts Drawing

WS 63 - Clamp -

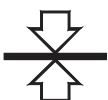
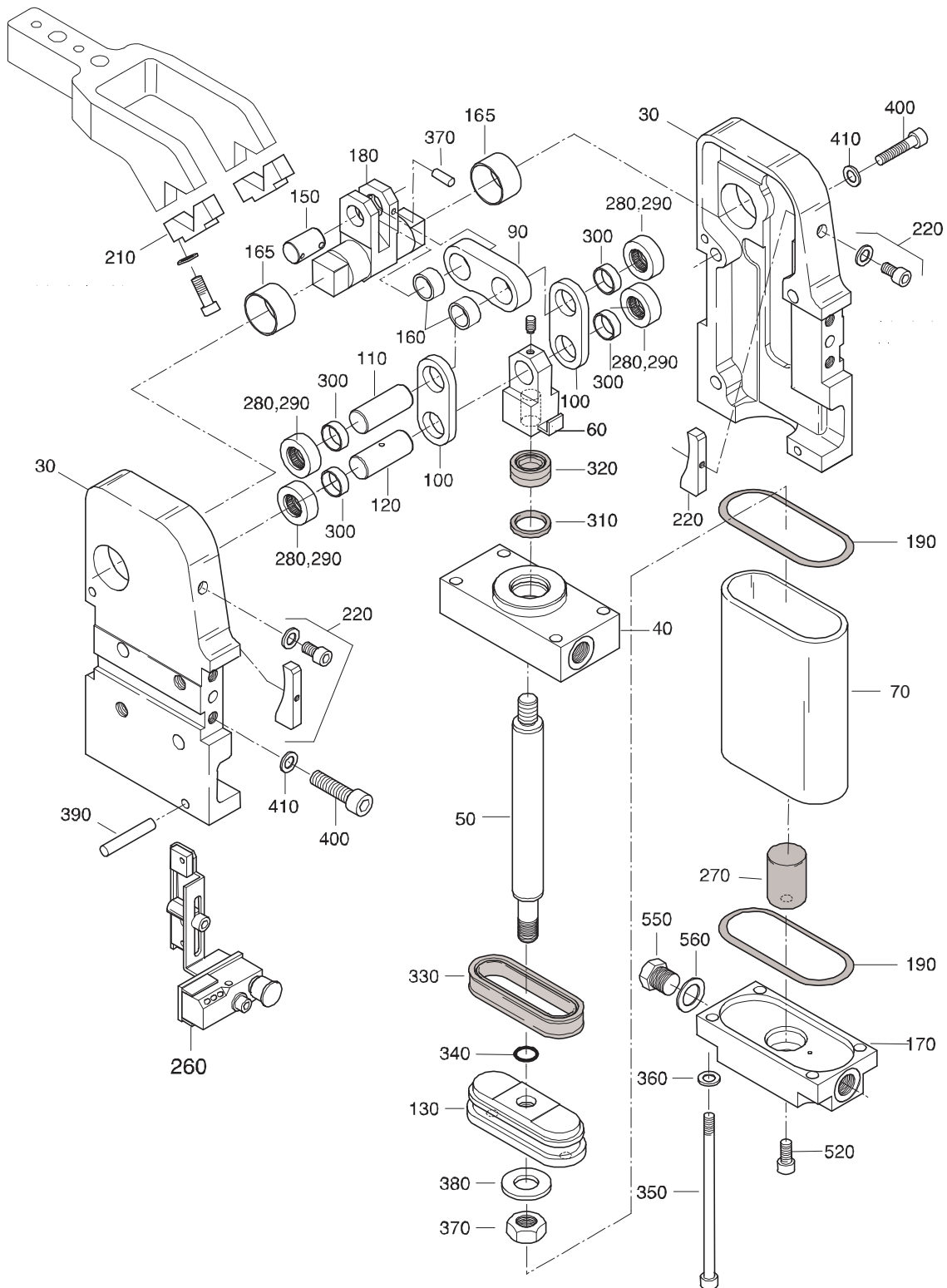

TÜNKERS®
SPANNSYSTEME

TÜNKERS® Maschinenbau GmbH
Am Rosenkoth 8 • D-40880 Ratingen
Postfach 10 17 16 • D-40837 Ratingen
Tel. 02102 4517-0 • Fax 02102 445808
Internet www.tuenkers.de



Spare Parts List

part-no. 243284

Clamp
WS 63 - 100 / 150 / 200

Spare Parts

05/09

Pos.	Part-No.	Quantity	Description	Type	
30	210544	1.00	housing	WS 63 - bend	
40	206992	1.00	cylinder head	K 63	
50	205035	1.00	piston rod	WMS	
60	230039	1.00	fork shaped piece complete	WS 63	
70	203321	1.00	cylinder pipe	FKSC 63	
90	226807	1.00	strap	VN 63	
100	205245	2.00	strap	WS 63	
110	226818	1.00	bolt	WS 63	
120	226818	1.00	bolt	WS 63	
130	204827	1.00	piston	K 63	
150	202609	1.00	bolt	FKSI 63	
160	205283	2.00	bush	FKSI 63	
165	201562	2.00	bush	28,0/31 x 13,0 DIN 17662	
170	202976	1.00	cylinder bottom	K 63	
180	203194	1.00	pintail	K 63	
190	201858	2.00	o-ring	76,00 x 2,00	
220	229812	2.00	supporting plate complete	WS 63	
260	215227	1.00	limit switch set complete	K 63 T12	
270	214100	1.00	buffer	FKSM 63	
280	206387	4.00	supporting roller	FKSI 63	
290	207336	144.00	needle roller	NRO B 1,5 x 5,8 G2	
300	227478	4.00	bearing bush	Ø 16/18 x 6	
310	212583	1.00	rod seal	Ø 20/29 x 28	
320	212539	1.00	scraper	Ø 20/28,6 x 6,5	
330	212061	1.00	cylinder seal oval	Y3 N 7894320-94	
340	201670	1.00	o-ring	12,0 x 2,0	
350	200208	4.00	hex. socket head cap screw	M 6 x 160 DIN 912	
360	200976	4.00	securing spring washer	S 6	
370	200708	1.00	hexagon nut	M 12 DIN 934	
380	205829	1.00	washer	FKSM 63	
390	201156	2.00	dowel pin	6 x 45 DIN 1481	
400	200224	7.00	hex. socket head cap screw	M 8 x 30 DIN 912	
410	200977	7.00	securing spring washer	S 8	
520	200164	1.00	hex. socket head cap screw	M 6 x 8 DIN 912	
550	201496	2.00	hexagon socket screw plug	G ¼ DIN 908	
560	201628	2.00	sealing ring	A14 x 18 x 1,5 ¼" DIN 7603	

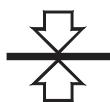

TÜNKERS®
SPANNSYSTEME

TÜNKERS® Maschinenbau GmbH
Am Rosenkoth 8 • 40880 Ratingen
Postfach 10 17 16 • 40837 Ratingen
Tel. 02102 4517-0 • Fax 02102 445808
Internet www.tuenkers.de



Spare Parts List

Guide unit with
spring compensator
WS 63 – 100 / 150
30 mm stroke

Spare Parts

05/09

Pos.	Part-No.	Quantity	Description	Type	Flag ¹
1	203921	1.00	housing	WMS	
2	203439	2.00	guide shaft	WMS	
3	230164	1.00	strap	WMS	
4	204951	1.00	piston rod	WMS	R
5	203424	1.00	guide bush	WMS	R
6	204754	1.00	piston	WMS	R
7	205841	1.00	washer	WMS	
9	1484509000	2.00	distance sleeve	WMS Ø 30,5 / Ø 20,5 x 8	
10	1484510000	2.00	distance sleeve	WMS Ø 30,5 / Ø 20,5 x 36	
13	201701	1.00	o-ring	20,0 x 2,5	R
14	201677	1.00	o-ring	15,0 x 2,0	R
15	227475	2.00	o-ring	24,0 x 2,0	R
16	227476	1.00	o-ring	7,0 x 1,5	R
18	212165	1.00	scraper	AS 15-25-5-8	R
20	201360	1.00	retaining rings for shafts	I 28 x 1,2	
21	227481	2.00	slotted round nut	M 18 x 1,5 DIN 1804	
22	227479	2.00	washer	5,5 DIN 125	
24	214644	2.00	hex. socket head cap screw	M 6 x 15 DIN 912	
29	225740	2.00	pressure spring	D-237	
32	227477	4.00	bush	SOB-203035	
34	227487	2.00	expander	MB 700-070	
33	209872	1.00	end-stop	HFS 200	
	232193	1.00	repair kit	WS 63-100/150	

¹ R = included with repair kit

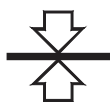

TÜNKERS®
SPANNSYSTEME

TÜNKERS® Maschinenbau GmbH
Am Rosenkoth 8 • 40880 Ratingen
Postfach 10 17 16 • 40837 Ratingen
Tel. 02102 4517-0 • Fax 02102 445808
Internet www.tuenkers.de



Spare Parts Drawing

Guide unit with
spring compensator
40 mm stroke

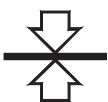
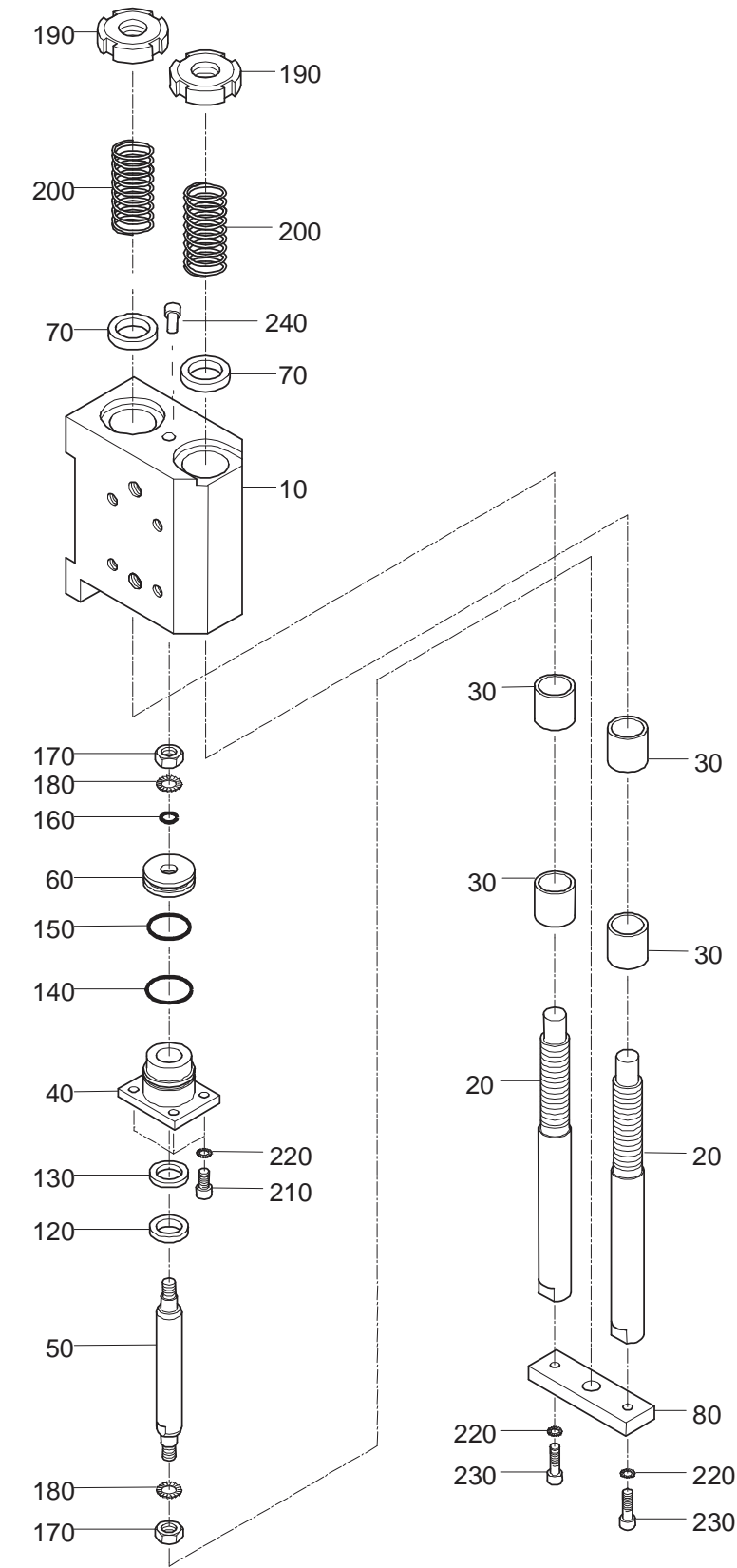

TÜNKERS®
SPANNSYSTEME

TÜNKERS® Maschinenbau GmbH
Am Rosenkoth 8 • 40880 Ratingen
Postfach 10 17 16 • 40837 Ratingen
Tel. 02102 4517-0 • Fax 02102 445808
Internet www.tuenkers.de



Spare Parts List

Art.-Nr. 243076

Guide unit with
spring compensator
WS 63 – 100 / 150 / 200
40 mm stroke

Spare Parts

05/09

Pos.	Part-No.	Quantity	Description	Type	Flag ²
10	242968	1.00	housing	WS 63/80	
20	233356	2.00	guide shaft	WS 80	
30	234854	4.00	guide bush	WS 63	
40	242965	1.00	guide bush	WS 63/WS 80	
50	243291	1.00	piston rod	WS 63/80 x 40 Hub	
60	204736	1.00	piston	PKS 32	
70	234853	2.00	distance ring	WS 63	
80	234852	1.00	strap	WS 63	
120	212181	1.00	scraper	16/22,0x 3,00/0,0	
130	210314	1.00	rod seal	Ø 16/Ø 25,0 x 2,8	
140	201729	2.00	o-ring	28,00 x 2,00	
150	201726	1.00	o-ring	26,00 x 3,00	
160	201664	1.00	o-ring	10,00 x 2,00	
170	200705	2.00	hexagon nut	M 8 DIN 934	
180	200977	2.00	securing spring washer	S 8,0	
190	252022	2.00	slotted round nut	M 18 x 1,5 DIN 1804 – h	
200	225740	2.00	pressure spring	Ø 27,50/2,50 x 115,0	
	256386	2.00	pressure spring	Ø 24,00/3,00 x 117,0	
210	222690	4.00	hexagon socket head cap screw	M 6 x 12 DIN 7984	
220	200976	4.00	securing spring washer	S 6,0	
230	200465	2.00	hexagon socket head cap screw	M 6 x 20 DIN 7984	
240	243705	1.00	bolt	WS 63	

² R = included with repair kit

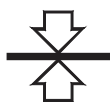

TÜNKERS®
SPANNSYSTEME

TÜNKERS® Maschinenbau GmbH
Am Rosenkothen 8 • 40880 Ratingen
Postfach 10 17 16 • 40837 Ratingen
Tel. 02102 4517-0 • Fax 02102 445808
Internet www.tuenkers.de