

Underbody Clamp

With locating pin, manually operated, toggle locked,
for pin Ø 20-40 mm, with moving device to protect the mechanism

MK 32.1 UZ

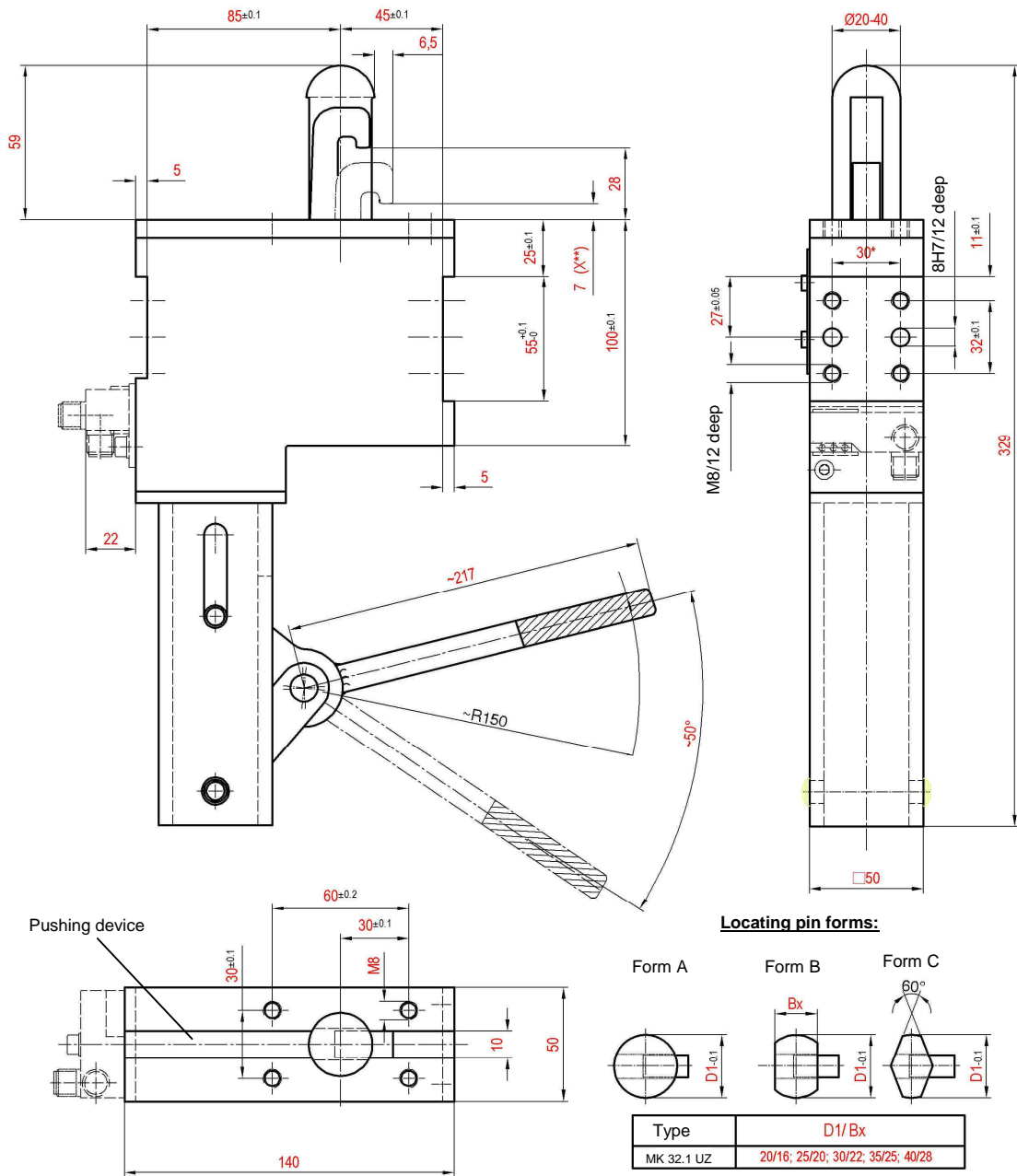

Ordering example:

MK 32.1 UZ T12 A 30 X
MK 32.1 UZ T12 B 30/22 X

MK 32.1 UZ: Type
T12: Sensing system
B: Locating pin form
30/22: Pin measurements D1, Bx
X: Sheet thickness

The hand lever is supplied unmounted.

**Measurements to order special designs.
Standard as shown.

*Tolerance for dowel holes ± 0.02 , for threaded
holes ± 0.1 .

Maximum load (***) depends on diameter of dowel pin and geometry of the hook.

Ordering example Tünkers sensing system:

...T00 Without sensing

Attention!

External throttle check valves must be provided on assembly.
They are not included in the scope of delivery!

Optional:

...T12 Inductive sensor 24 V, 1 output
with integrated LEDs

Type	***Holding force max.	***Clamping force	Weight (kg)
MK 32.1 UZ	250 daN	180 daN	2,4