

Electric Clamp

totally enclosed, self-locking type, with electric motor

EK 25.1 A10

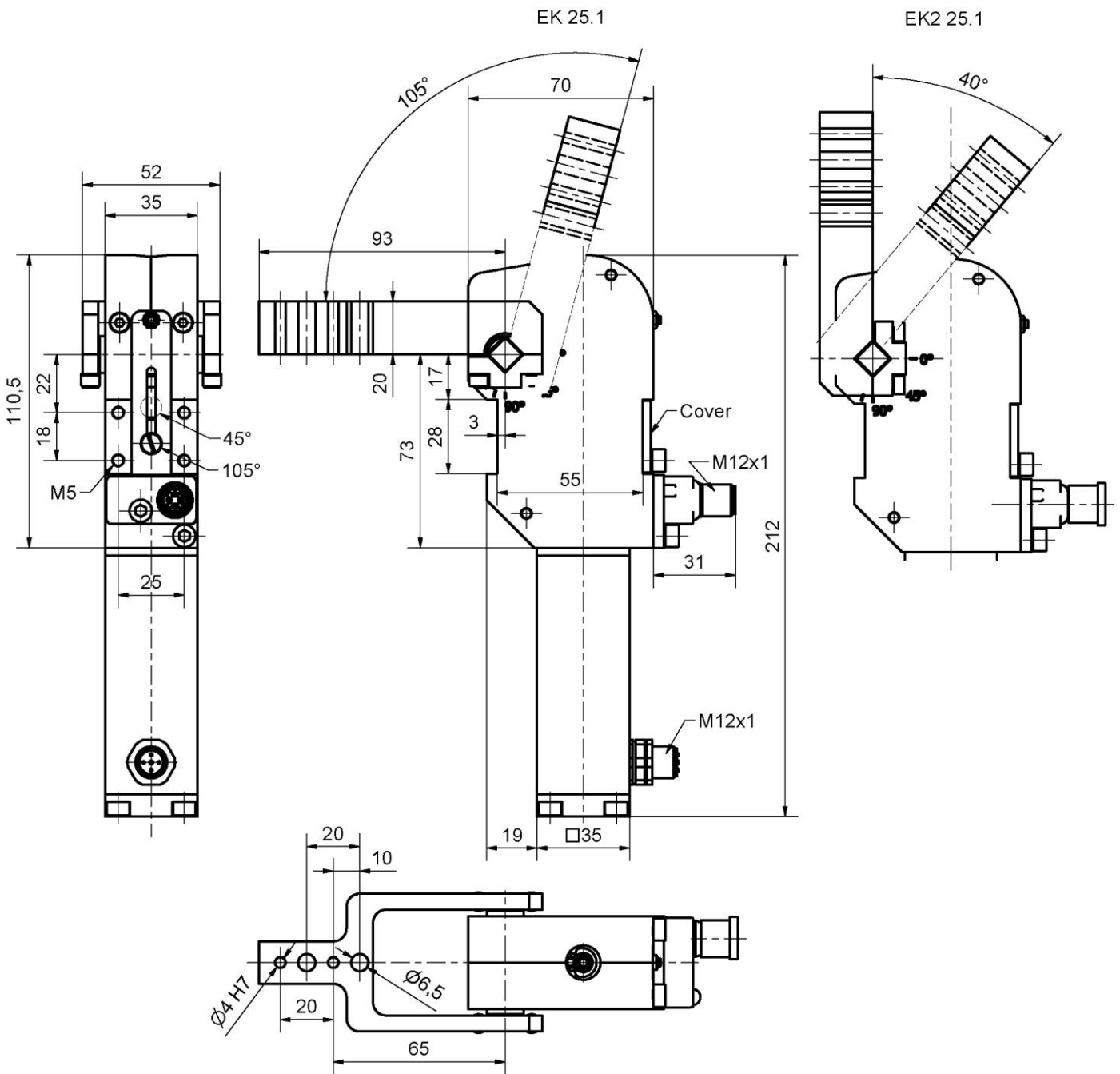

Ordering example:

EK 25.1 A10 T12 105°

EK 25.1: Type
 A10: Clamp arm version
 T12: Sensing system
 105°: Opening angle

Ordering example Tünkers sensing systems:

...T00 Without sensing system
 ... T12 Inductive sensor 24 V, 1 output with integrated LED's

Technical data:

Holding torque max. :	75 Nm
Clamping moment:	25 Nm
Corresponds to piston Ø:	25 mm
Weight kg:	1,5
Nominal voltage V:	24
Rotational speed:	1200 min ⁻¹
Power W:	20
Protection type DIN 40050:	IP 54
Cycle time (sec):	0,9
Off-time min. (sec):	3,5

* Tolerance for dowel holes ± 0.02, for threaded holes ± 0.1.