



Operation Instructions Retractable Pin Cylinder

SZK 30.7

19/11/12

1. Description

The retractable pin cylinder is a high-power tool designed for use in locating points in the processing of sheet metal. It consists of a pneumatic cylinder in a housing with integrated piston rod guiding and mountings at the side.

The retractable pin cylinder is fitted with an inductive set, which allows positioning to be controlled with inductive switches.

2. Safety

The retractable pin cylinder was not conceived as a full tool supplied ready for independent use and has therefore not been fitted with its own safety equipment. Only when it is correctly installed in a production system and a corresponding safety control system is added, will all safety requirements be met.

Should any faults occur that place personnel at risk, the retractable pin cylinder is to be switched off immediately. Maintenance measures are only to be undertaken when the machine is at a complete standstill and by suitably qualified specialists.

After maintenance work has been carried out, the protection devices are to be refitted in the correct way.

3. Assembly of the retractable pin cylinder

- The retractable pin cylinder is installed by means of four head cap screws on the housing sides.
- The centering pin manufactured by the customer is secured in the piston rod receiver with a threaded pin M6X10 or a spring type straight pins.
Caution: The retractable pin cylinder was not provided with means of adjustment. This must be taken into account when designing / manufacturing the consoles / braces.

Create supply of compressed air between pneumatic control and retractable pin cylinder (connections "N").

Caution: For fine adjustment of speed of positioning operation use of external regulating valves is recommended.

A. Inductive limit switch set (T12)

Set plug on socket "C" according to the electrical design of the pneumatic clamp (see circuit diagrams), and tighten.

Caution: Operation with incorrect or too high voltage can lead to short circuiting and danger to personnel.

Function control with integrated LED as follows:

green operation voltage

yellow cylinder up

red cylinder down

4. Replacement of limit switch cartridge

- Remove limit switch cartridge by releasing the screws "D".
- Set new limit switch cartridge and assemble.

5. Maintenance

The retractable pin cylinder is fitted with a view to application in series production with low-maintenance bearings and guides. Because of the closed structure of the retractable pin cylinder no special maintenance is necessary.

Caution: Damage can be caused to the retractable pin cylinder by cleaning with steam-jet or dry ice.

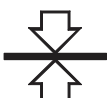
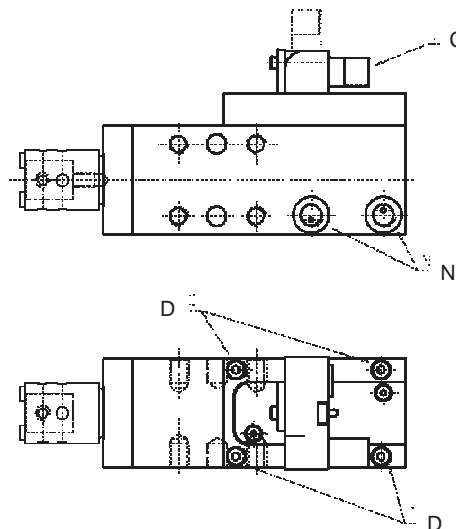

TÜNKERS®
SPANNSYSTEME

TÜNKERS® Maschinenbau GmbH
Am Rosenkothen 8 • 40880 Ratingen
Postfach 10 17 16 • 40837 Ratingen
Tel. 02102 4517-0 • Fax 02102 445808
Internet: www.tuenkers.de



Operation Instructions Retractable Pin Cylinder

19/11/12

Detection set T12

Inductive switch, 1 connector

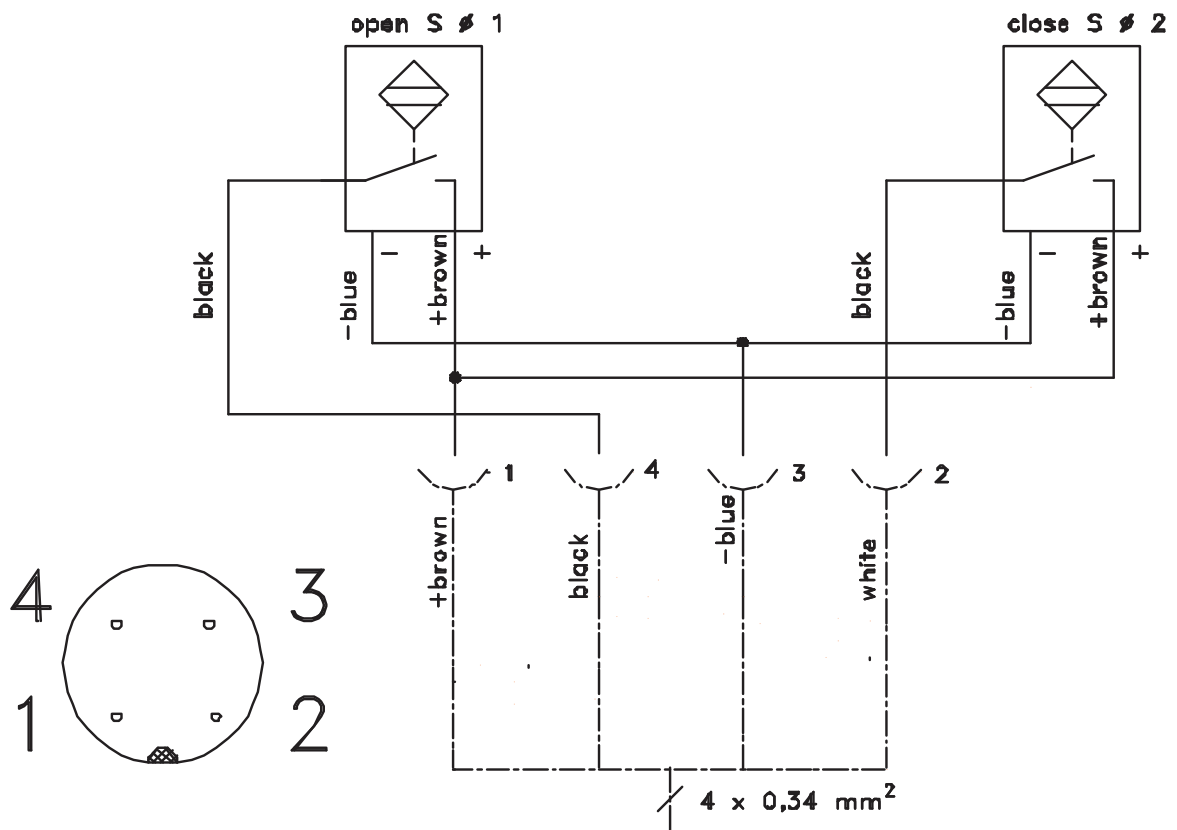
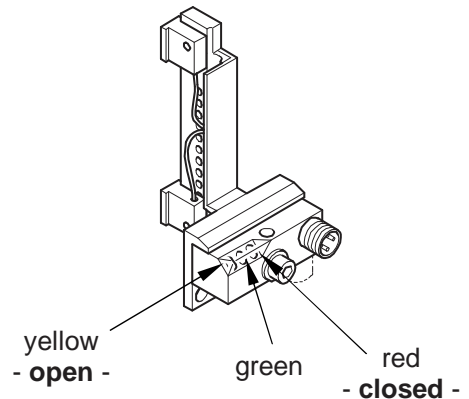

Technical Specifications

Inductive switch (Standard version)

Short circuit proof

Rated voltage 10-30 V

Working current 32 mA (one initiator connected with PLC)

Closer PNP exit

protective insulation according to DIN VDE 0100

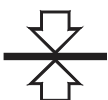

TÜNKERS®
SPANNSYSTEME

TÜNKERS® Maschinenbau GmbH
Am Rosenkoth 8 • 40880 Ratingen
Postfach 10 17 16 • 40837 Ratingen
Tel. 02102 4517-0 • Fax 02102 445808
Internet: www.tuenkers.de