

Shims

K 25, 40 / K 50 – 80 / V 50.1 – V 80.1 series

AP...

Ordering example:

Order no. 260384: AP 4001 for K 25 / K 40

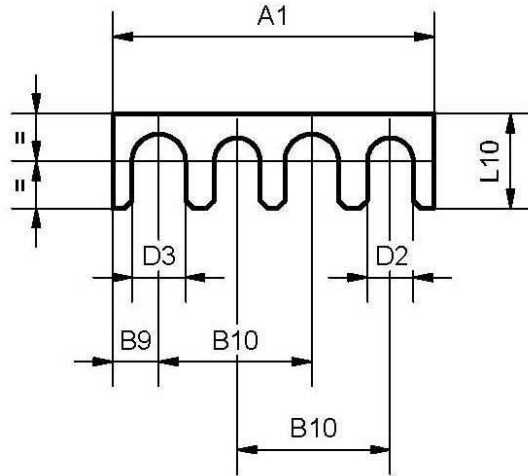

Ordering example:

Order no. 260412: AP 4305 for K 25 / K 40

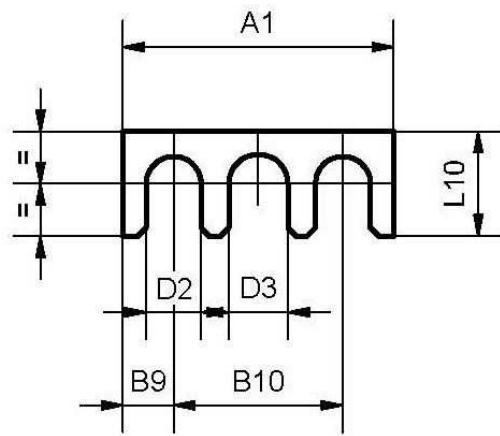

Shims type	for Clamp	A1	A2	D2	D3	B9	B10	L10	Order no.	Quantity delivered /piece							
AP 4001	K 25 / K 40	AP 40.. = 42 AP 43.. = 32	0.1	6,5	7	6	20	12,4	260384	50							
AP 4301			0.1						260410	50							
AP 4002			0.2						260385	50							
AP 4302			0.2						260411	50							
AP 4005			0.5						260304	250							
AP 4305			0.5						260412	100							
AP 4010			1.0						260374	250							
AP 4310			1.0						260413	250							
AP 4020			2.0						260375	500							
AP 4320			2.0						260456	250							
AP 4050			5.0						260386	20							
AP 4350			5.0						260458	25							
AP 5001-20			K 50-80 V 50.1-80.1						AP 50.. = 60 AP 53.. = 45	0.1	9	9	7,5	30	20	260402	20
AP 5301-20										0.1						260408	50
AP 5002-20	0.2	260403		20													
AP 5302-20	0.2	260409		50													
AP 5005-20	0.5	260399		100													
AP 5305-20	0.5	260405		50													
AP 5010-20	1.0	260400		250													
AP 5310-20	1.0	260406		50													
AP 5020-20	2.0	260401		250													
AP 5320-20	2.0	260407		50													
AP 5050-20	5.0	260404		20													
AP 5350-20	5.0	260459		25													

