

Vario Clamp

Stepless adjustable opening angle

V/V2... .1 BR3

5° – 135°

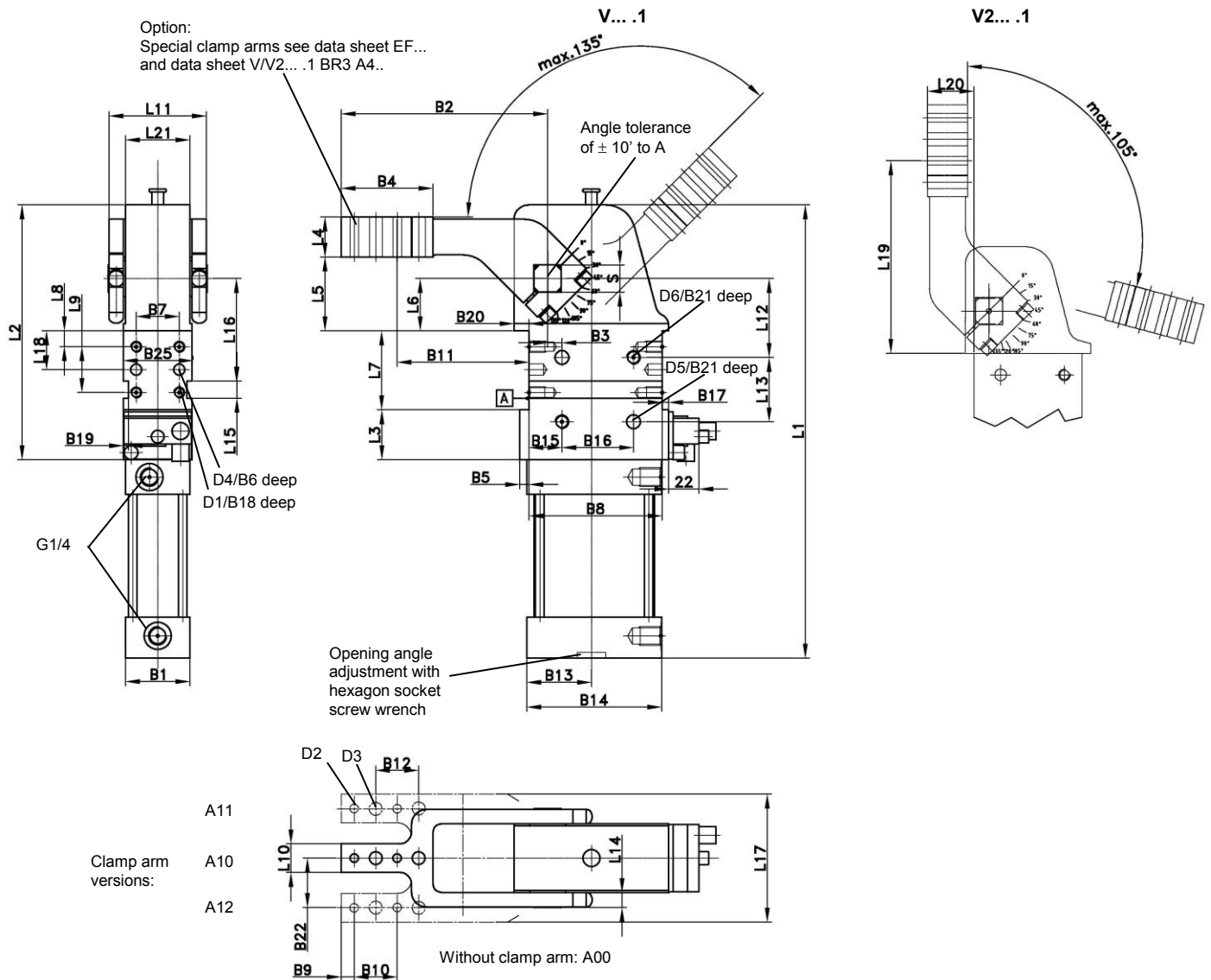

Ordering example:

V 50.1 BR3 A10 T12

V 50.1 BR3: Type
A10: Clamp arm version
T12: Sensing system

Ordering example TÜNKERS sensing system:

... T12: Inductive sensor 24 V, 1 output with integrated LED's

Standard opening angles:

Stepless adjustable in the range of 5° to 135° (Type V... .1).

*Tolerance for dowel holes ± 0.02, for threaded holes ± 0.1.

Medium: Air, max. 6 bar, operation permitted with oil-free air.

Attention!

External throttle check valves must be provided on assembly. They are not included in the scope of delivery!

Type	Holding torque max.	Clamping moment at 5 bar	Corresp. piston Ø (mm)	Weight ~ (kg)	B1	B2	B3 ±0,05	B4	B5	B6	B7*	B8*	B9	B10 ±0,02
V/V2 50.1	800 Nm	160 Nm	50	3.9	45	144	10	65	6.5	12	30	93	9	30
V/V2 63.1	1500 Nm	380 Nm	63	4.8	52	144	10	65	7.5	12	30	93	9	30
V/V2 80.1	2500 Nm	800 Nm	80	14	62	179	15	65	8	12	50	134	9	30

Type	B11 ±0,1	B12 ±0,2	B13	B14	B15 ±0,1	B16*	B17	B18	B19	B20	B21	B22 ±0,1	B25	D1	D2 H7	D3	D4 H7	D5 H7	D6	L1	L2	L3
V/V2 50.1	92	30	47	94	23	50	4.5	12	3.5	10.5	12	34	48	M8	6	9	8	10	M10	321	178	35
V/V2 63.1	92	30	54	106	23	50	7.5	12	3.5	12	12	37	54	M8	6	9	8	10	M10	335	185	35
V/V2 80.1	119	30	70	140	36	70	8	15	3.5	20	13	50.5	76	M10	6	9	8	12	M12	488	270	55

Type	L4 ±0,1	L5 ±0,2	L6 ±0,05	L7 +0,1	L8 ±0,1	L9 ±0,1	L10	L11	L12 ±0,05	L13*	L14 ±0,1	L15 N9	L16 ±0,05	L17	L18 ±0,05	L19 ±0,1	L20 ±0,2	L21	S H9
V/V2 50.1	28	51.5	36.5	55	11	32	20	69	55	45	10	12	71.5	88	27	141.5	30	45	19
V/V2 63.1	28	51.5	36.5	55	11	32	20	79	55	45	10	12	71.5	94	27	141.5	30	52	22
V/V2 80.1	35	70	50	80	15	50	25	109	65	75	12.5	12	96.5	126	40	190	34	74	30