

Vario Power Clamp

Operating Instructions

V... .1 BR2 BG
V... .1 BR2, BR3 Z
VU... .1 BR2, BR3 Z
V... .1 LW

1. Description

The Vario Power Clamp is a high performance tool, developed primarily for sheet metal assembly tasks. The clamp consists of a pneumatic cylinder, a metal housing – mountable on any of four sides – and a clamping arm to which the clamping NC Block is attached.

In the clamping operation, the cylinder acts upon an integrated toggle linkage, actuating the clamp arm and intensifying the pressure. The position of the clamping arm is indicated by an integrated position sensing cartridge.

2. Safety

Since the Vario Power Clamp is designed not to be an independent complete tool, it is not equipped with any unique safety measures or devices. Safety requirements can be met only when properly installed into an assembly system, according to prescribed safety regulations.

In case of malfunction, which may endanger personnel, operation of the Vario Power Clamp must be terminated at once. Maintenance must only be performed by properly trained personnel with the system stopped.

After system service procedures are completed, all safety devices must be properly reinstalled prior to operation.

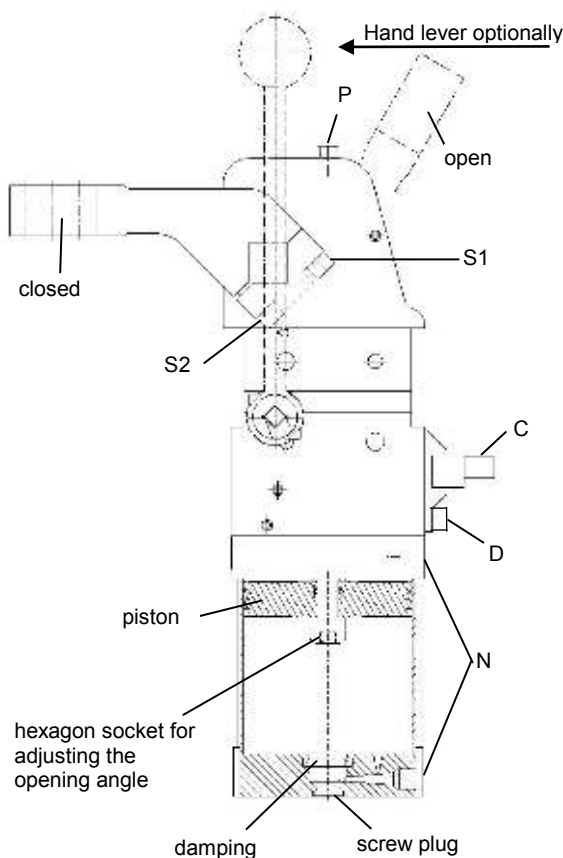

Fig. 1: Clamp

3. Installation of Vario Power Clamp

- The clamp is mounted on one of four housing sides using screws and dowels.
- It is mandatory to adhere to the minimum screw-in depth.

Front and rear side attachment:

	V 50...	V 63...	V 80...
Thread size	M8x12	M8x12	M10x15
Screw-in depth min. [mm]	9	9	11
Tightening torque max. [Nm]	25	25	48

Lateral attachment:

	V 50...	VU 50...	V 63...	V 80...
Thread size	M10x12	M8x12	M10x12	M12x13
Screw-in depth min. [mm]	11	11	11	12
Tightening torque max. [Nm]	48	25	48	84

- Pipes or hoses connect the clamp to the control valve. Installation of flow control valves is necessary to both ports to reduce the clamp opening and closing speed and to adjust to the proper system / line speed.

Attention: The Vario clamp is equipped with an integrated cushion on the return stroke. At excessive clamp arm weight, the safe function of the cushion is not warranted. Maximum permitted clamp arm weight design guidelines must be adhered to.

A. Inductive Position Sensing (T12)

Connect sensor per electrical diagram to control line by inserting connector "C" and tightening connector coupling nut.

Caution: Operation with wrong current or current higher than specified may short out the system and lead to personnel injury.

Function of the integrated LEDs is as follows:

green System current
red Clamp closed
yellow Clamp open

Vario Power Clamp

Operating Instructions

V... .1 BR2 BG
V... .1 BR2, BR3 Z
VU... .1 BR2, BR3 Z
V... .1 LW

B. Clamp arm mounting

The bars of the flange have different heights. Note the alignment of the flange during assembly, see fig. 2 a and 2 b.

Tighten screw "S1" first (no gap between cap and arm body) and then screw "S2" (remaining gap).

Use only the supplied fastening elements. Shorter screws will lead to damage of the clamp arm.

Clamp arm versions size 50

A10	A40	
M 6 x 25		
	steel version	aluminum version
Screw	12.9	min. 8.8
Tightening torque	17 Nm	10.2 Nm
Conical spring washer	DIN 6796-6-FSt.	

Clamp arm versions size 63

A10	A40	
M 8 x 30		
	steel version	aluminum version
Screw	12.9	mind. 8.8
Tightening torque	41 Nm	25 Nm
Conical spring washer	DIN 6796-6-FSt.	

Clamp arm versions size 80

A10	A40
M 10 x 40	

Steel version:

Screw 12.9

Conical spring washer DIN 6796-10-FSt.

Tightening torque 80 Nm

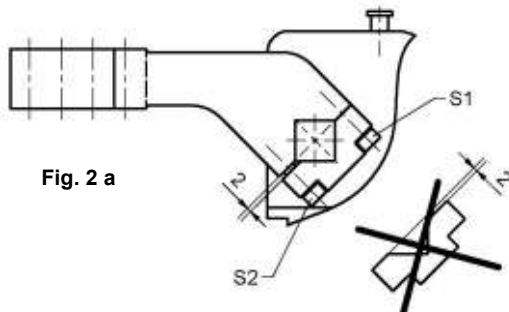

Fig. 2 a

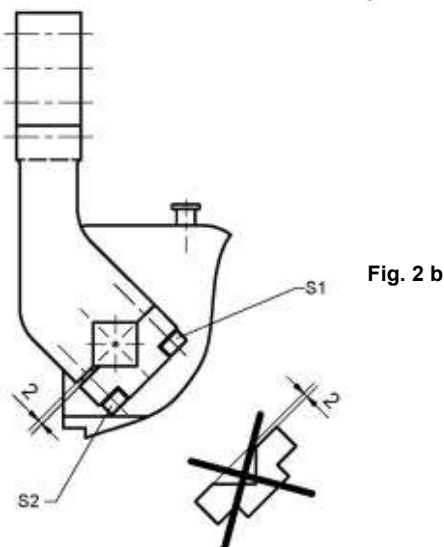

Fig. 2 b

4. Blocking system "BG"

The version "BG" Vario Power Clamps are equipped with a mechanical locking system acting in „closed“ direction. In case of a spontaneous failure of the compressed air supply, the movement of the clamp arm in "closed" direction will be prevented. In this case, the holding force will be at least 50% of the nominal force.

IMPORTANT:

Exceeding of this holding force can destroy internal components or can cause shorter lifetime, even if the holding function applies for a short time.

Blocking system "BG"

The blocking system consists of balls which are arranged in a cone concentric to the piston rod. The balls are pressed into the cone by spring force. This leads to jamming of the piston rod in the intended movement direction for closing.

The locking is released automatically with the pneumatic control of the clamp in "closed" direction.

At zero pressure the clamping of the piston rod on the flow side is available in any position of the clamp arm

Important:

When the clamp is used for dynamic applications on grippers, the forward stroke must be pressurised shortly, before actuating the return stroke. This leads to a safe releasing of the piston rod brake.

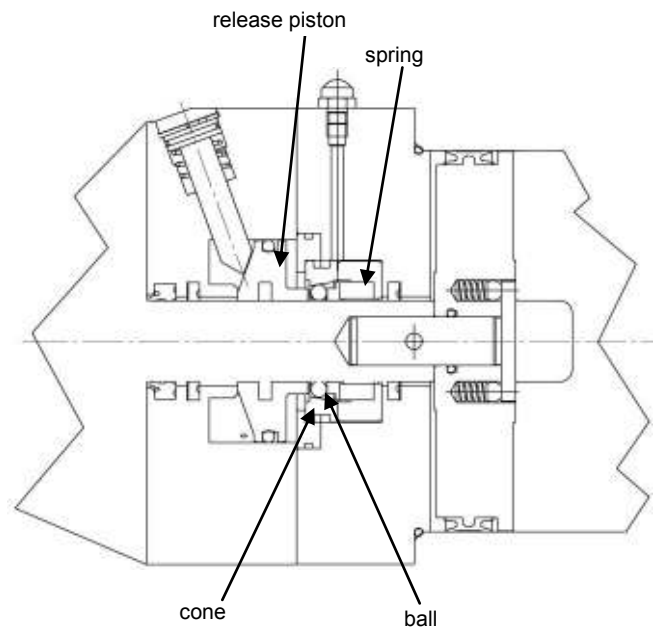

Fig. 3: Drawing V... .1 BR2 BG

Subj



Vario Power Clamp

Operating Instructions

V... .1 BR2 BG
V... .1 BR2, BR3 Z
VU... .1 BR2, BR3 Z
V... .1 LW

5. Adjustment of the Vario Power Clamp

Attention! Before the contour (N/C) block is disassembled, the clamp arm must be removed from the clamp! This is the only way to avoid damage to the clamp.

Caution – Pinching Danger!

During adjustment of the clamp arm, fingers can be pinched, cut, or severed. While clamp is in setup, try out or in operation, stay clear of mechanism. Remove air supply to clamp prior to working in clamping area.

- Attach contour (N/C) block to clamp arm.
- Close clamp. Toggle links must move to locked position. The release pin “P” is in extended position.
- Determine dimensional difference between arm/contour block and part.
- Open clamp.
 - a) Set-up with no clamping pressure (soft-touch)
 Set dimensional stack-up to .0 mm through installation of proper size ground spacers or “net” blocks (see fig. 4). Please note the OEM project specifications!
 - b) Set-up with clamping pressure
 Set dimensional stack-up to + .5 mm through installation of proper size ground spacers or “net” blocks.
- Close clamp. The toggle mechanism travels past the zero (straight) position and locks, accomplishing the required tension.

The clamp can be opened and closed via hand lever in version “Z” when the cylinder is depressurised, max. manual force 200 N (at a lever length of 200 mm) = 40 Nm.

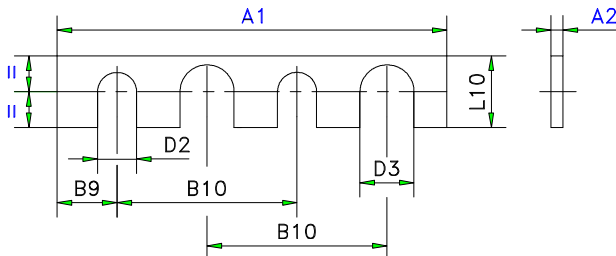

Ground Spacer no.	A1	A2	D2	D3	B9	B10	L10
AP 5005		0,5					
AP 5010	65	1,0	6,5	9	10	30	16

Fig. 4: Ground spacer - example

6. Breaking the toggle lock

The toggle mechanism can be unlocked, when the clamp arm is in closed (locked) position, by pressing the unlock pin “P”.

In version “Z” the clamp can be opened via hand lever.

CAUTION: Danger of Pinching: Pressing the unlock pin “P” may cause the clamp arm to jump to open position. Keep hands out of clamp arm movement range.

7. Changing the opening angle

The opening angle on the Vario Power Clamps is infinitely adjustable within the standard range of 5°-135°, for the "Z" version 5°!-120°. Changing the opening angle also changes the end of stroke cushion and the position sensors.

Attention! The opening angle of the Vario Power Clamps with sensing system T08T may not be changed by the customer!

Set Up:

- Bring clamp arm to open position.
- Read the pre-adjusted angle at the scale.
- Remove the locking screw in the cylinder bottom.
- Screw the hexagon socket at the piston rod until the desired opening angle is reached.
- Mount the locking screw at the cylinder bottom.

CAUTION: Look out for a correct fastening and seat of the seal, because the inner space of the cylinder is sealed this way.

With changing the opening angle, the position of the trip cam changes automatically, so it is not necessary to set it separately.

When mounting the clamp arm in position 2 (see fig. 2 b), the max. opening angle is 105°!

8. Changing of position sensing cartridge

- Remove position sensing cartridge by loosening screws "D".

Caution: Move clamp arm to the open position before replacing the position sensing cartridge!

9. Changing of position of the air connections

If absolutely necessary, the air connections "N" can be positioned at the front of the clamp by the following procedure:

- Bring pneumatic clamp into the opened position.
- Remove position sensing cartridge by loosening screws "D".
- Loosen the screws at the bottom of the cylinder and remove the drive cylinder.
- Rotate the cylinder bottom and the cylinder head by 180° so that the air connection is positioned at the front.
- Re-assemble the cylinder and tighten the screws at the cylinder bottom.

Attention: It is absolutely mandatory that the trip cam is seated properly in the housing guide (see fig. 5).

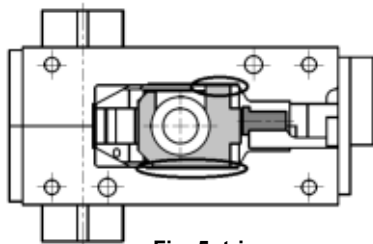

Fig. 5: trip cam



10. Changing of clamp arm

To assure proper positioning and the repeat of clamp arm position of the replacement clamp arm tighten screw "S1" first (Zero opening between cap and arm body) and clamp the arm by tightening screw "S2".

Recommended torque:	V 50.1:	17 Nm / 150 in/lb
	V 63.1:	41 Nm / 360 in/lb
	V 80.1:	80 Nm / 710 in/lb

11. Maintenance

Bearings and wear faces on the Vario Power Clamp have been designed with consideration for high production applications. This technical concept allows 3 million cycles without significant component wear.

Attention: To provide protection from welding slag and other debris, the clamp is equipped with a fully closed housing. Therefore, no special maintenance is required. Cleaning with high-pressure steam or dry ice may damage the power clamp.

Option "BG"

In regular intervals, at least every 100,000 cycles, the blocking system must be tested at its function. For this purpose, the clamp must be placed in the pressure-less state and the clamp arm must be set into a position between 10° and 135°. If the clamp arm will be pulled into the closed position by hand force (50% of the maximum allowable holding torque must not be exceeded), the clamp arm must not yield more than 5° before the blocking unit accesses. The unit must be exchanged immediately if the blocking function is not given or if the allowable angle range is exceeded.

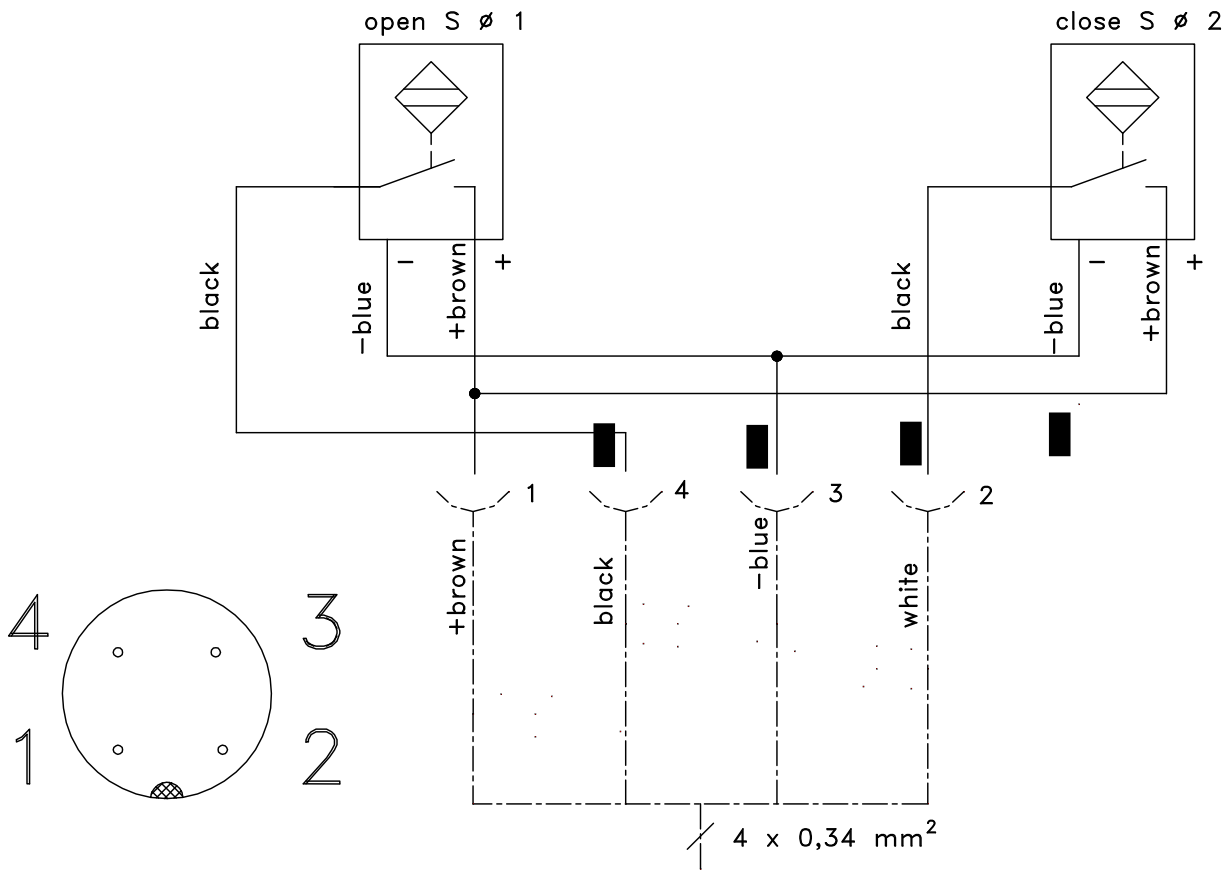
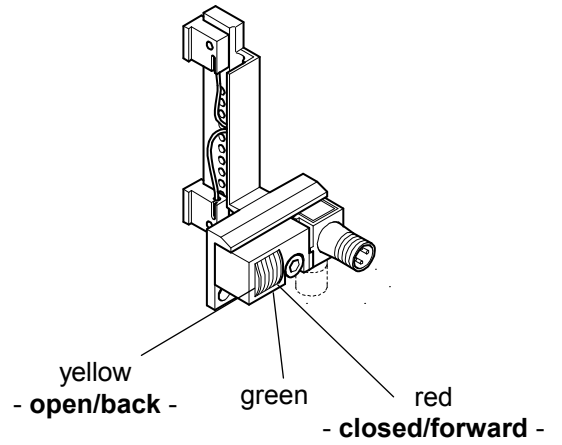

Technical Specifications

Inductive switch (Standard version)

Short circuit proof

Rated voltage

Working current

Power

10-30 V

32 mA (one initiator connected with PLC)

PNP exit

